

NATIONAL SUPERCONDUCTING CYCLOTRON LABORATORY PROPOSAL FOR EXPERIMENT

Date Submitted: _____ Experiment # _____
(Assigned by NSCL)

TITLE: Commissioning and characterizing the High Resolution Array (HiRA)

SPOKESPERSON: Mark Wallace

Address: NSCL/MSU

Phone: 333-6469 Fax: 353-5967 E-Mail Wallace@nscl.msu.edu

BACKUP SPOKESPERSON: Mike Famiano

Institution: NSCL/MSU

Phone: _____ Fax: _____ E-Mail _____

Is this a thesis experiment? **Yes** No If yes, for whom? Mark Wallace

OTHER EXPERIMENTERS: (please spell out first name)		Check, if applicable	
Name	Organization	Grad	Sr. Grad
William G Lynch	NSCL		
Andrew Rogers	NSCL	XXX	
Giuseppe Verde	Texas A&M		
Romauldo De Souza	IUCF		
Sylvie Hudan	IUCF		
Lee Sobotka	Washington University		
Robert Charity	Washington Unviersity		
Arialdo Moroni	INFN Milano		

REQUEST FOR PRIMARY BEAM SEQUENCE INCLUDING TUNING, TEST RUNS, AND IN-BEAM CALIBRATIONS (summary of the detailed beam delivery time calculation.)

	Isotope	Energy (MeV/nucleon)	Beam delivery time (Hours)	On-target time (Hours)
Primary beam 1	¹⁶ O	150	6	16
Primary beam 2	⁷⁸ Kr or ⁹⁶ Mo	140	0	48
Primary beam 3	⁷⁸ Kr or ⁹⁶ Mo	140	6	32
Primary beam 4	⁷⁸ Kr or ⁹⁶ Mo	140	0	16
Primary beam 5	¹⁶ O	150	6	72

TOTAL REQUESTED HOURS: 202 (Calculated as per item 4. of the Notes for PAC27 in the [Call for Proposals](#))

HOURS APPROVED: _____

HOURS RESERVED: _____

DESCRIPTION OF EXPERIMENT

(no more than 4 pages of text - 1 1/2 spaced, 12pt; no limit on figures or tables)

Please organize material under the following headings or their equivalent:

1. Physics justification, including background and references.
2. Goals of proposed experiment
3. Experimental details—apparatus (enclose sketch); what is to be measured; feasibility of measurement; count rate estimate (including assumptions); basis of time request (include time for calibration beams, test runs and beam particle or energy changes); technical assistance or apparatus construction required from the NSCL.
4. Status of previous work done at the CCF.

Physics justification:

The HiRA detector addresses a need identified at the Berkeley workshop [1] on the instrumentation required for effective exploitation of the scientific opportunities at RNB facilities; i.e. a large solid angle, segmented, position sensitive, high-resolution charged-particle detector array for inverse-kinematics nuclear structure and reaction studies. It is designed so that it can be reconfigured to provide the necessary angular coverage for these studies. It is portable and can be run in a stand-alone mode or in conjunction with other devices such as the S800 spectrometer. It can be moved between experimental vaults at the NSCL and outside of the NSCL for experiments at other advance rare isotope facilities.

HiRA is an array of charged particle telescopes shown schematically in Figures 1 and 2. It consists of 20 individual telescopes each containing a 65 μm thick single sided silicon strip detector, a 1.5 mm double sided silicon strip detector, and 4 CsI(Tl) crystals read out by silicon photo diodes behind them. There are 32 strips on the active area of 6.2 mm^2 with an inter-strip gap of 25 μm on the junction side and 40 μm on the ohmic side of the silicon.

Because of the large number of silicon strips used in the device (2000) it was not financially feasible to utilize currently existing technology for signal processing; therefore, as part of the HiRA project an Application Specific Integrated Circuit (ASIC) has been designed for the processing of the large number of silicon strips. Each ASIC chip consists of 16 preamplifiers, 16 Shapers, 16 Discriminators, and 16 TAC's. The control of these chips will be performed by FPGA and will be multiplexed out to a flash ADC. This type of electronic readout reduces significantly the number of electronic modules needed for very complex experiments. Replacing the single flash ADC would require roughly 60 VME ADC units and replacing the ASIC's would require 2000 preamps, 120 16 channel CAMAC shapers, 120 16 channel CAMAC discriminators, and 120 16 channel CAMAC TDC's, for example. This ASIC design approximately reduces the electronics cost by a factor of 30. This cost reduction is achieved by making miniature circuits that are so different from their full scale analogs that we cannot rely on our experience with conventional electronics to accurately anticipate problems. Instead both elaborate simulations and rigorous testing are required.

The HiRA will be finished at the end of 2003. To prepare for the its scientific program, commissioning experiments are needed.

Goals of the proposed experiment:

The HiRA device relies extensively on computer controlled pulsed electronics and computer controlled tracking and calibration procedures to achieve its design resolution. While much can be learned with the use of α sources and pulsers, some tests require beams from the cyclotron to perform thorough checks. Our goals are to make sure the electronics works properly, to know the uniformities and calibrations of the detectors, and to know how to combine the device with beam tracking detectors and other ancillary devices. We must perform tests that require specialized device configurations and running modes that are not compatible with the setup and performance criteria of a running experiment. Below, we list the tests that are needed and specify the requirements of each of the required tests.

Experimental Details:

Here we list the main objectives, requirements and timeline for the proposed measurements. (A complete list and explanation of secondary objectives would require many pages.) We begin with a table of the beams, number of shifts, location, number of telescopes, ancillary detectors, and proposed timeline:

Test #	Beams	shifts	location	#telescopes	ancillary det.	timeline
1	Z = 1-8 frag. beam	2	92" chamber	2	Std PPAC	Dec. 2003
2	Ar or heavier primary beam	6	92" chamber	20	None	Feb. 2004
3	78Kr or 96Mo. beam/fragments	4	92" chamber	20	2 MCPs	Mar. 2004
4	78Kr beam	2	S800	20	S800/PPCA/MCPs	May 2004
5	Z=1-8 cocktail beam	9	92" chamber	20	None	Fall 2004

All runs can accept a broad range of primary beams. For the runs with secondary beam, we will require only a rough idea of what fragments we have in the A1900 before we send beam to vaults. We therefore request the minimal time to develop secondary beams in our beam time request.

Test 1: The main objective of this measurement is to discover problems with the performance of the silicon or CsI detectors or with the chip electronics running either in "forced readout" mode. One of the two telescopes will use the chip electronics. The other telescope will use conventional electronics. We are particularly concerned about the problems caused by cross talk, in the silicon strips, the CsI(Tl) crystals or the electronics, which may appear at high random rates.

Justification for beam test: With alpha source test one can deposit up to 8.7 MeV into a silicon detector. At this energy we observe some cross talk or charge splitting between neighboring strips via the small inter-strip gap. During an experiment one could expect to see several hundred MeV of energy deposition into the silicon. One can put a pulser into the chip to look at cross-talk in the chip but that will not tell us what happens on the silicon or in the cables that are built into the silicon design. The pulser system is designed to pulse every other channel simultaneously; we can't pulse a single channel. (If one thinks about the topology of a pulser system that can individually pulse selected channels out of the 2000 in HiRA, it becomes clear why individual pulsing was not a feature included in the design.) If the test reveals a cross talk problem, we may need to modify the electronics hardware. Currently the trigger logic is programmed on an FPGA chip that is mounted on the motherboard. If the changes in the trigger logic for readout are substantial, one might have to reroute traces on the motherboard to accommodate the new trigger program on the FPGA.

Test 2: The main objective of this measurement is to test the readout for the HiRA array in its normal running configuration. This involves FPGA programmed trigger logic for each telescope as well as the FPGA residing in the VME crate. We are particularly concerned here about possible problems with noise and with misidentifying the data words that may appear at high rates. Secondary objectives include determining whether zero suppressed sparse readout works for the thin silicon detectors and making first measurements of the non-uniformities of the silicon detectors thickness.

Justification for beam test: The trigger logic of HiRA involves coincidences between thick and thin silicon detectors, between silicon detectors and CsI detectors, and between multiple detectors. Beam is needed to generate realistic coincidence events between them. The problems with pulsers is again the limitation of pulsing every other channel on a given detector so you can't check whether a coincidence between one strip in the front silicon and another in the back is working properly as it must during an actual experiment.

Test 3: The objectives of this measurement are: 1) to test whether the timing from the ASIC's is influenced by event rate or event length and 2) to search for rate dependent problems with the kinematics reconstruction of reverse kinematics experiments using HiRA and the MCP tracking detectors.

Justification for beam test: 1) The timing information for the HiRA strips is stored on sample and hold circuits for a variable time delay depending on event length and is subject to noise that depends on event rate. Correcting a variable delay problem would require running the experiment in forced readout and the purchase of additional adc's to process the additional data words that would entail. If noise were determined to be a problem, more detailed studies with simulations and sources would be needed to discover a solution. 2) Present resolution tests of the MCP's using beam and shadow masks have provided information about the full width at half maximum of the position resolution, but little information about the tails of the resolution

function and about how the resolution function changes with count rate. We propose to determine these tails from the energy spectra of protons and deuterons backscattered from a CH₂ target.

Test 4: The main objective of this measurement is to merge the data acquisition systems of the S800, HiRA, 2 MCPs, 2 PPACs in the beam line, and timing scintillators already in the A1900.

Justification for beam: All current experiments on the books require HiRA to be measured in conjunction with beam tracking counters and most require coincidence with the S800. Tests with the Beam provide is the only way to make sure the data packets from the various devices are merged properly. It is important to test this separately from an experimental run because the pressures of an actual experiment make it difficult to complete the testing in real time. Indeed, there have been cases where the on line testing indicated that the data were being taken properly only to find problems in the merging of data from different devices in the later analyses.

Test 5: The main objective of this measurement is to develop a calibration of the non-uniformities of the CsI crystals and map the thickness variation for the silicon detectors.

Justification for beam: The CsI crystals have isotope dependent light output non-uniformities that must be calibrated with beam. In the past, experiments using CsI(Tl) detectors have typically devoted 2-3 shifts for a calibration of modest accuracy. Over the life of the Miniball, a week and a half of beam time was so used. For the LASSA, we used about 4 days. Such calibrations cannot be done efficiently and accurately with the telescopes assembled in an array, as they would ordinarily be configured during an experiment. Instead, one must place the detectors on an assembly so that they can be individually inserted into the beam. We propose to do this in one run efficiently and accurately and then construct standard response functions that can be adopted by subsequent users. We plan to do this after the completion of the transfer reaction experiment Exp 02018 and the breakup experiment Exp 02023 because the former does not require an accurate energy calibration and the latter is largely self-calibrating. Delaying this calibration will ensure that the running configuration for HiRA is stable and that the calibration is meaningful for later use.

Status of previous work at CCF:

We have 3 approved experiments from PAC 26, none of which have been preformed. They both require the completion of the HiRA device.

References:

1. ISOL Instrumentation Workshop, December 1998, I.Y. Lee ed.

2. SAFETY INFORMATION

It is an important goal of the NSCL that users perform their experiments safely, as emphasized in the [Director's Safety Statement](#). Your proposal will be reviewed for safety issues by committees at the NSCL and MSU who will provide reviews to the PAC and to you. If your experiment is approved, a more detailed review will be required prior to scheduling and a [Safety Representative](#) needs to be designated.

SAFETY CONTACT FOR THIS EXPERIMENT: Mike Famiano

HAZARD ASSESSMENTS (CHECK ALL ITEMS THAT MAY APPLY TO YOUR EXPERIMENT):

- Radioactive sources required for checks or calibrations.
- Transport or send radioactive materials to or from the NSCL.
- Transport or send— to or from the NSCL—chemicals or materials that may be considered hazardous or toxic.
- Generate or dispose of chemicals or materials that may be considered hazardous or toxic.
- Mixed Waste (RCRA) will be generated and/or will need disposal.
- Flammable compressed gases needed.
- High-Voltage equipment (Non-standard equipment with > 30 Volts).
- User-supplied pressure or vacuum vessels, gas detectors.
- Non-ionizing radiation sources (microwave, class III or IV lasers, etc.).
- Biohazardous materials.

PLEASE PROVIDE BRIEF DETAIL ABOUT EACH CHECKED ITEM.

We will use alpha sources to calibrate and test the detectors before, during and after the beam times.
We must bias our detectors which several hundred volts as well as some MCP detectors that will be used for tracking.

Figure 1.

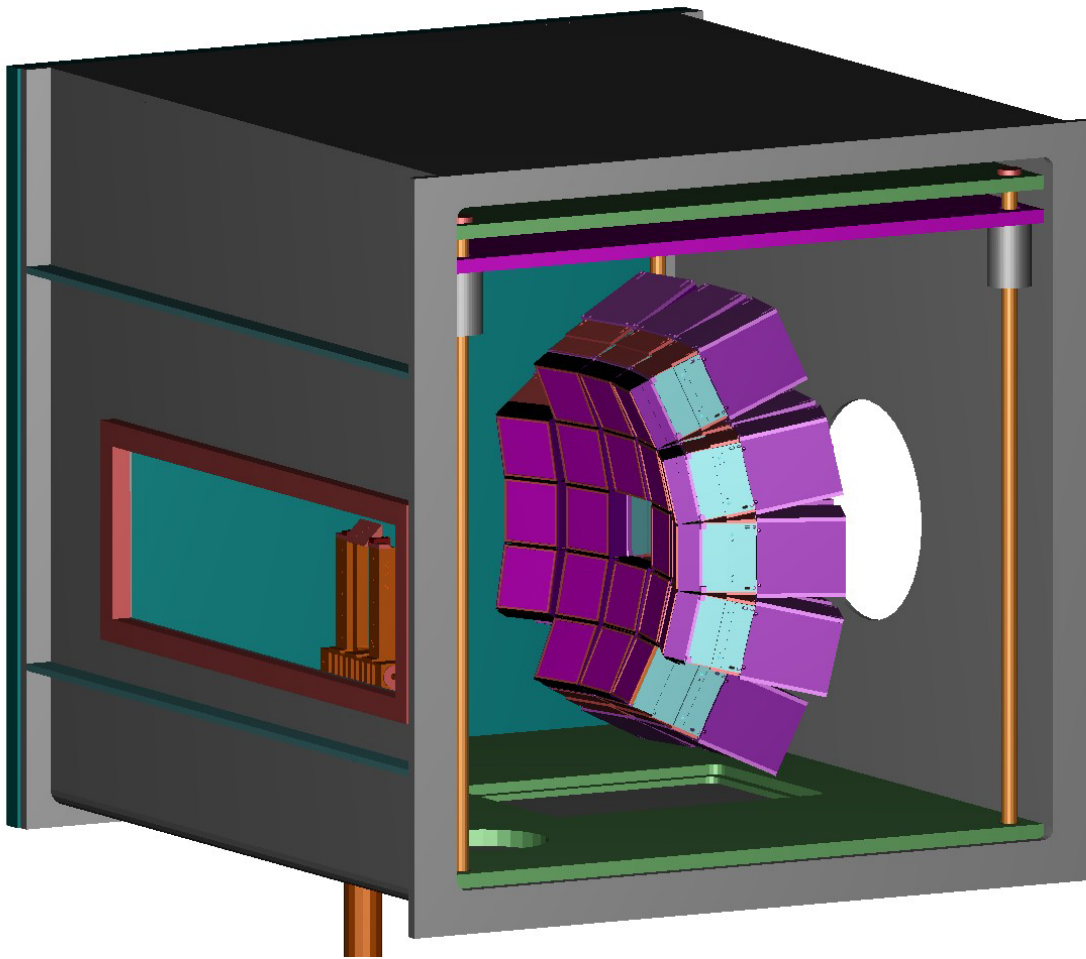

Figure 2

